



NOT1293  
01.21

# Sanicom2

The user should retain these instructions for future reference  
À lire attentivement et à conserver à titre d'information  
El usuario debe mantener estas instrucciones para futura referencia



\*option

## IMPORTANT/ IMPORTANTE DO NOT RETURN ANY MERCHANDISE TO THE VENDOR NE PAS RETOURNER DE MARCHANDISE AU VENDEUR NO REGRESE NINGUNA MERCANCÍA AL VENDEDOR

For Customer Service, Returns or Technical Questions, please call Saniflo's Technical support toll-free at 800-571-8191 (USA) or 800-363-5874 (CDN).

Pour le service client, les retours ou toute question technique, merci d'appeler le service technique de Saniflo au numéro suivant : 800-363-5874 CDN

Para servicio al cliente, devoluciones o preguntas técnicas, por favor llame al soporte técnico de Saniflo sin cargo al 800-571-8191 (USA)

This product must be installed in strict accordance with local plumbing codes. Product should be installed by a licensed plumber.  
Le produit doit être installé dans le respect des règlements sanitaires locaux. Le produit doit être installé par un plombier qualifié.  
El producto debe ser instalado en estricto acuerdo con los códigos locales de plomería.  
El producto debe ser instalado por un plomero con licencia.



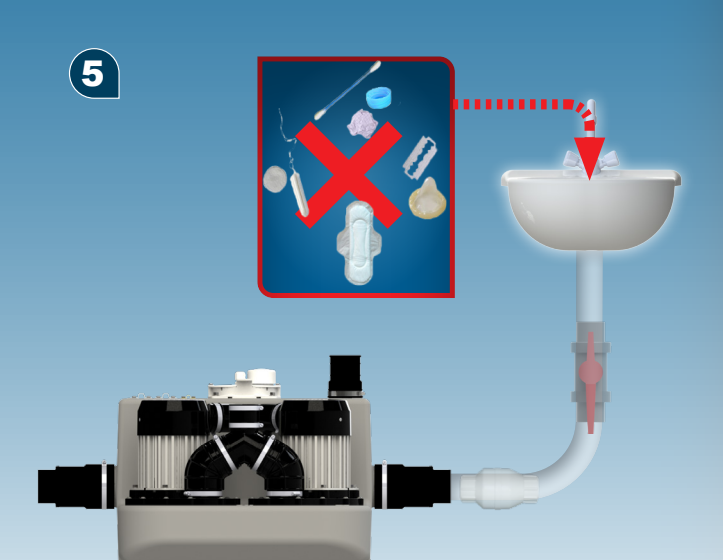
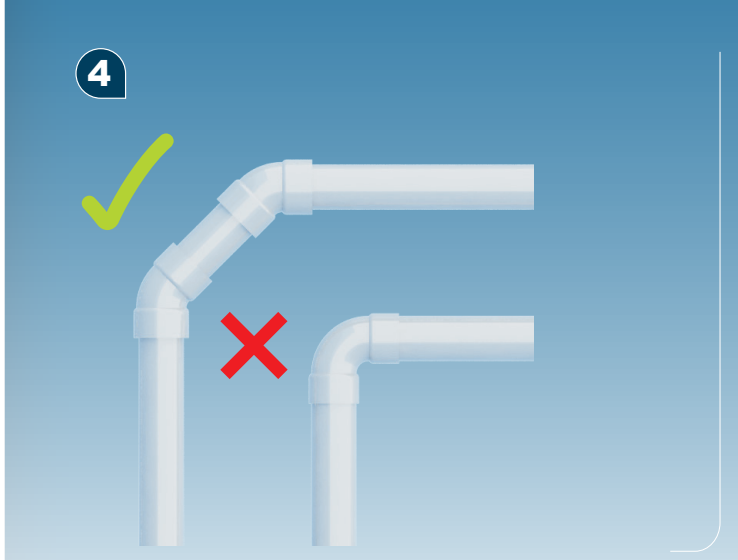
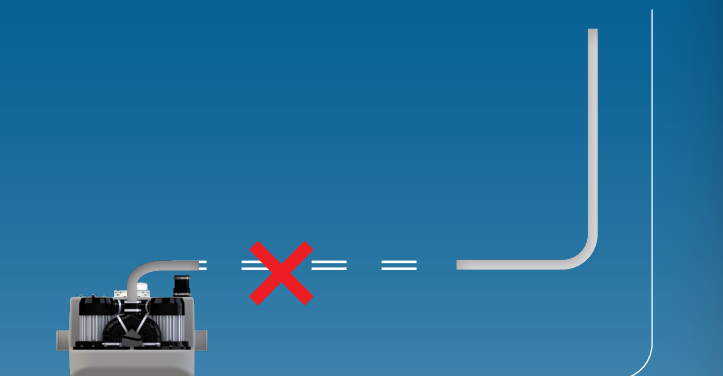
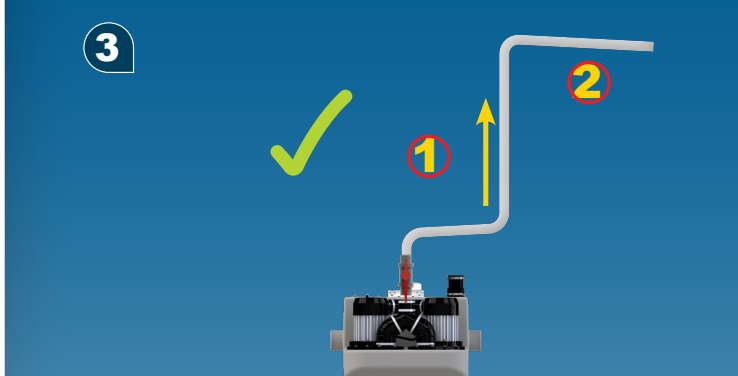
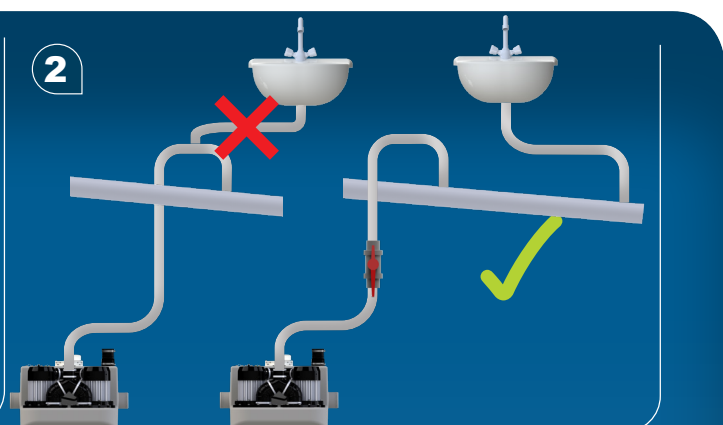
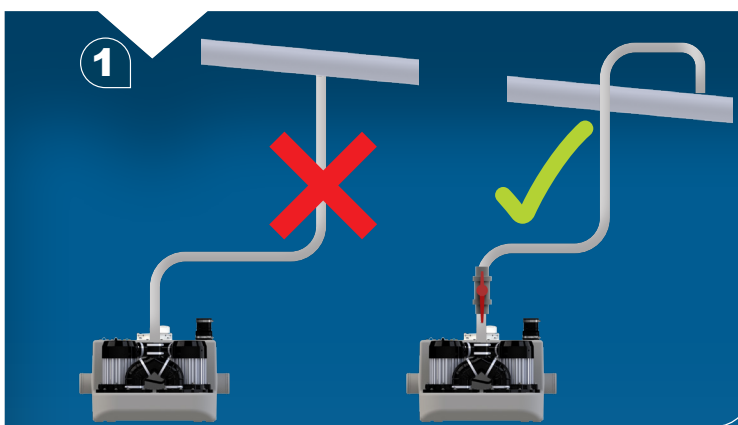
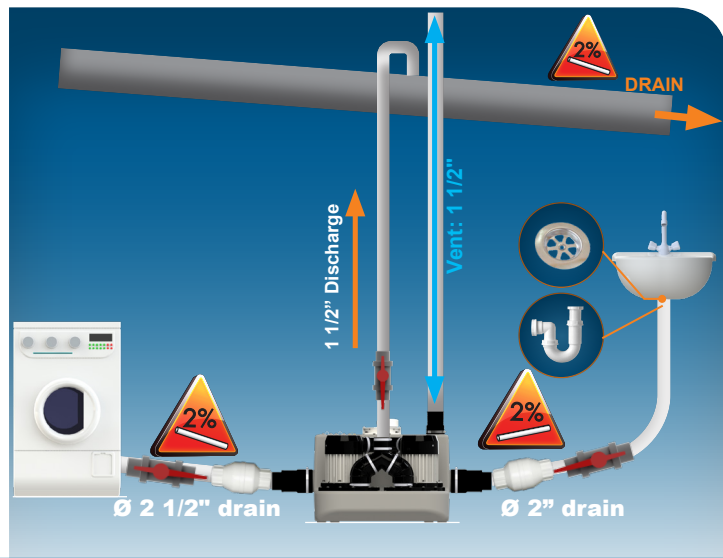
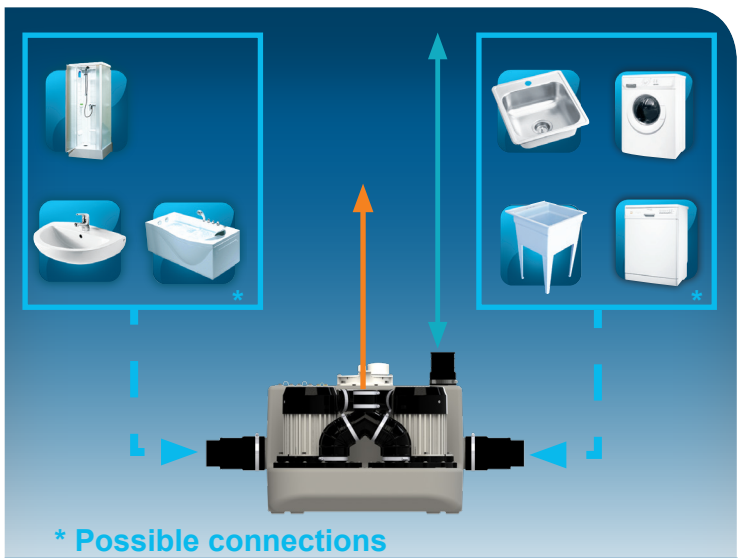

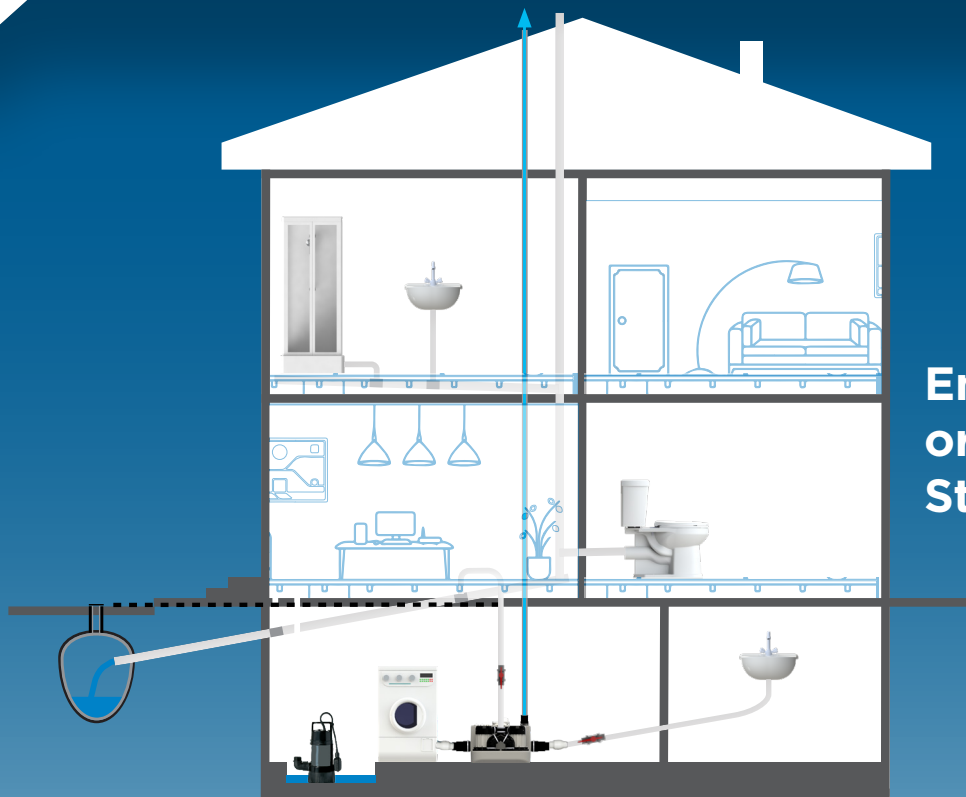

Entire Homes  
or Building  
Structures

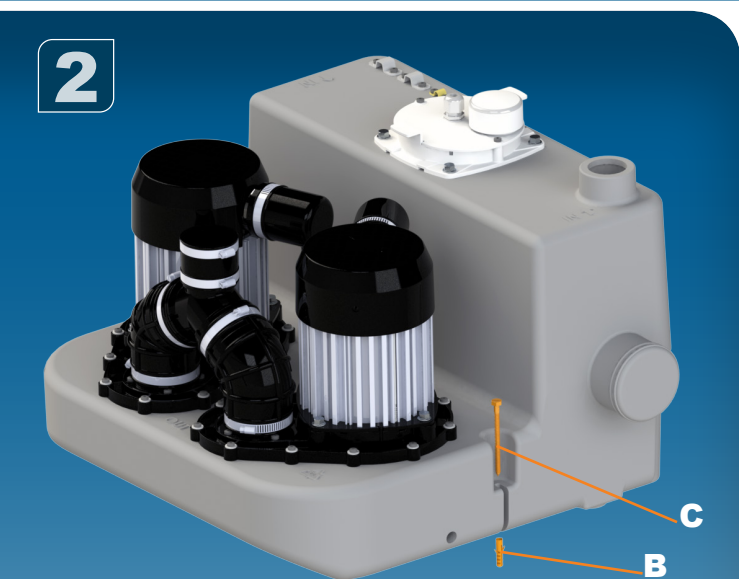
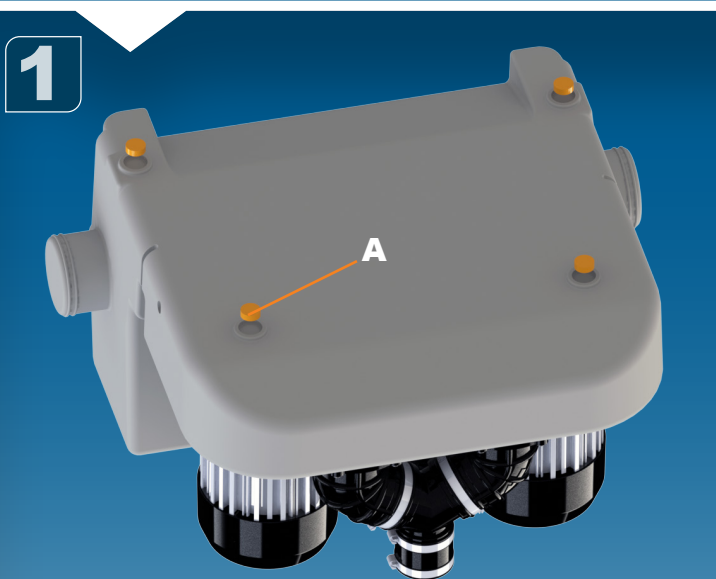
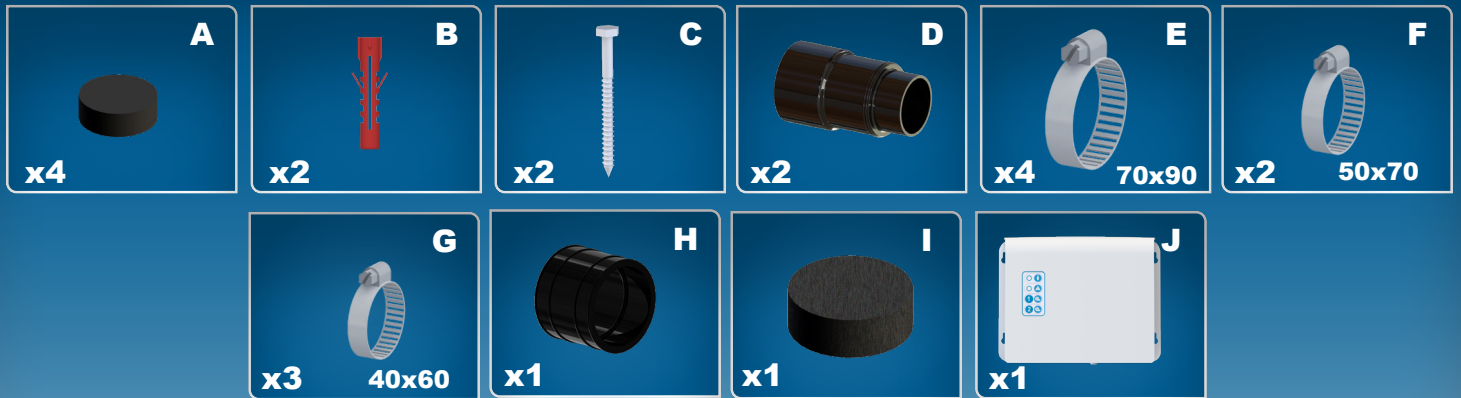

3

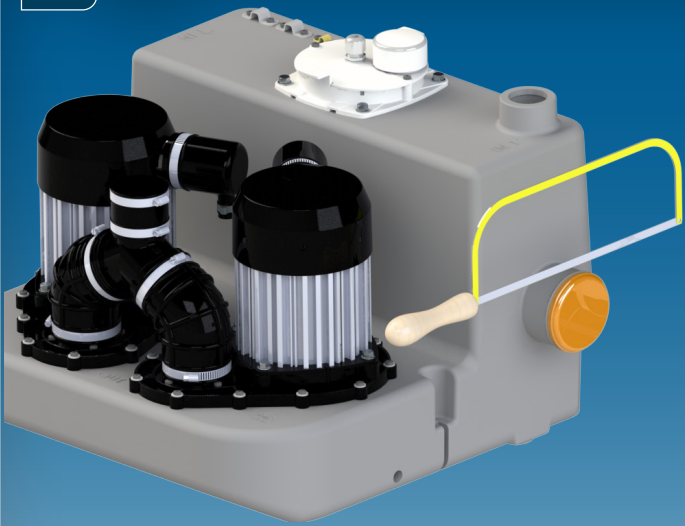

4

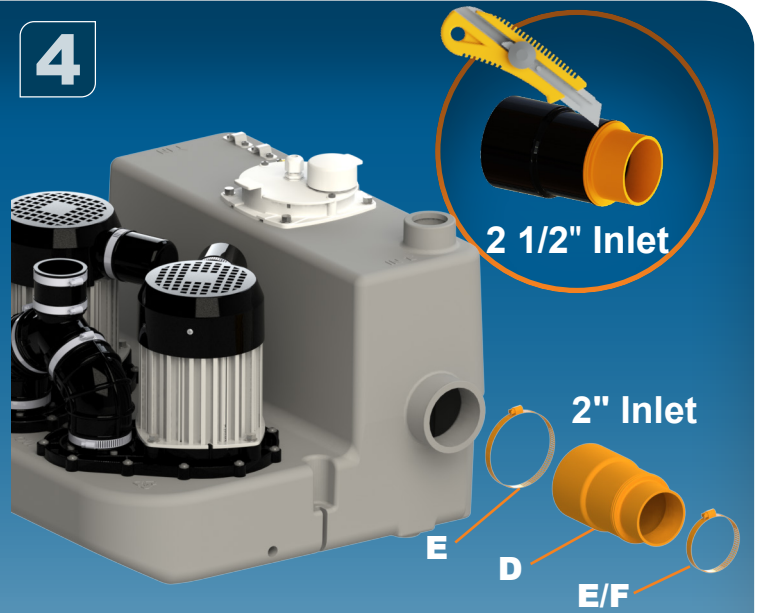

5



6

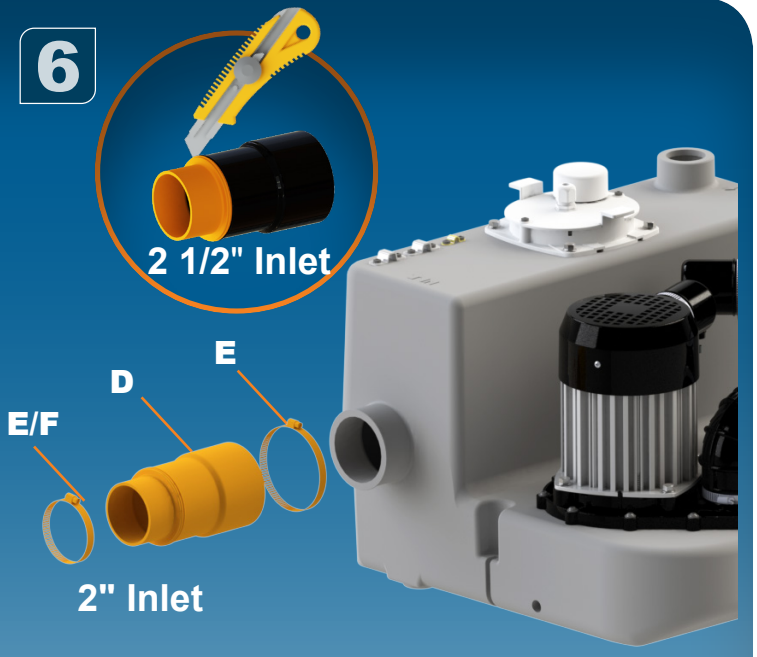

7

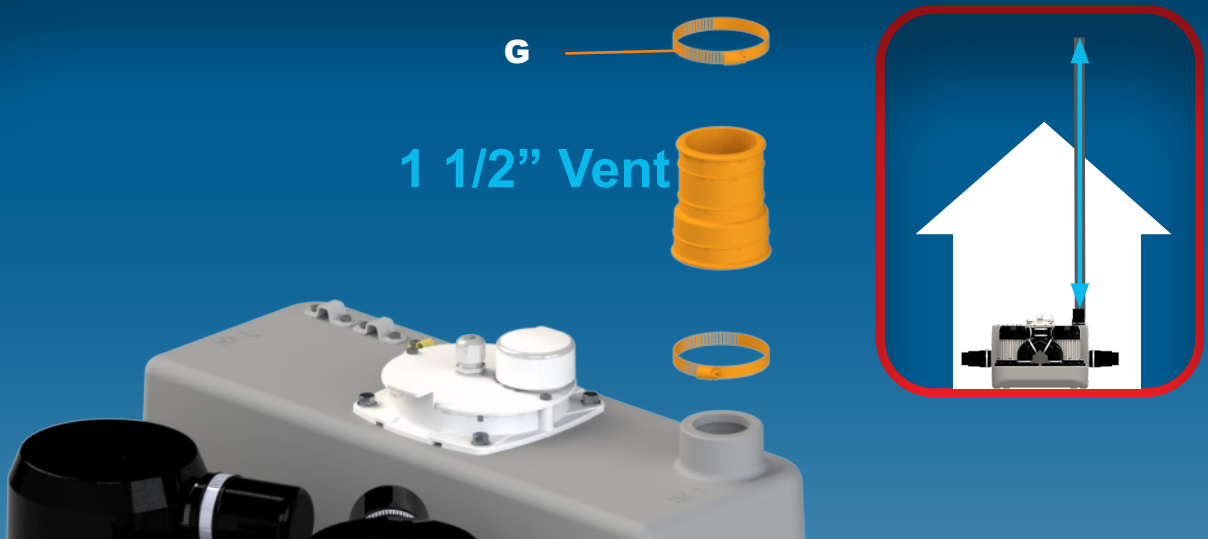

8

1 1/2" Inlet

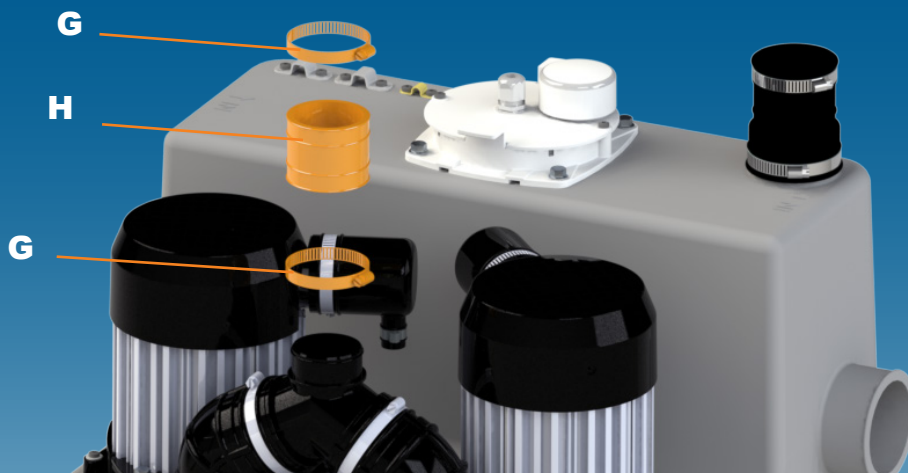

9

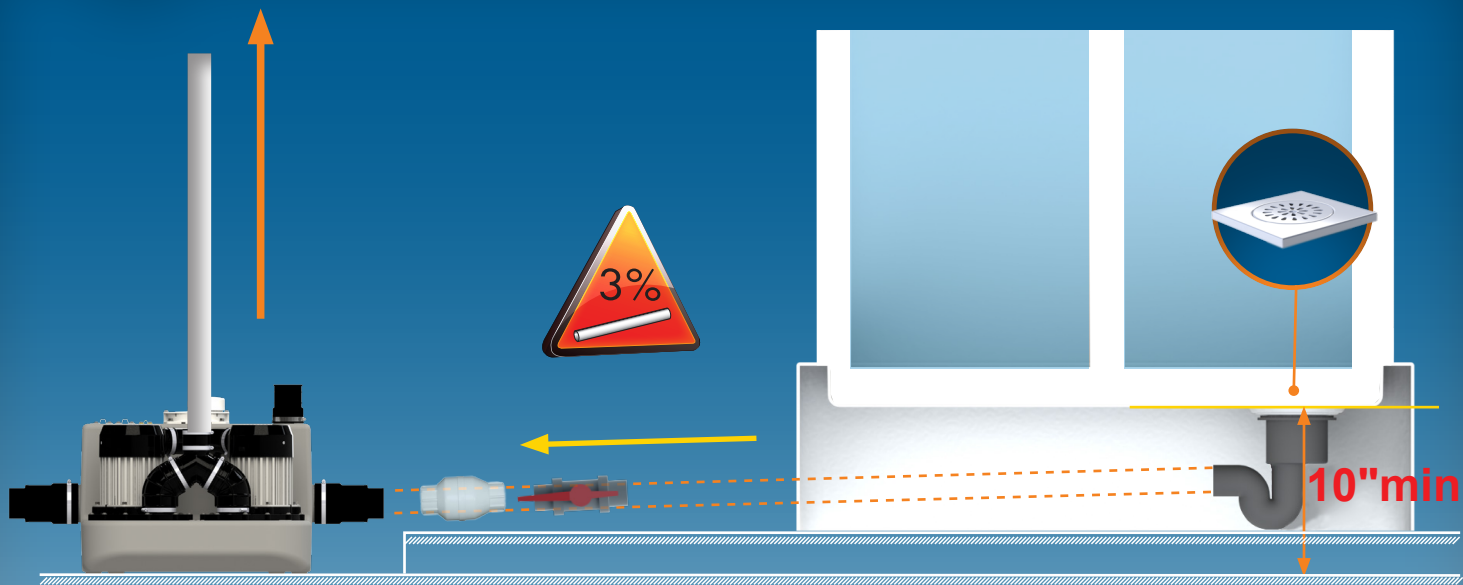

10

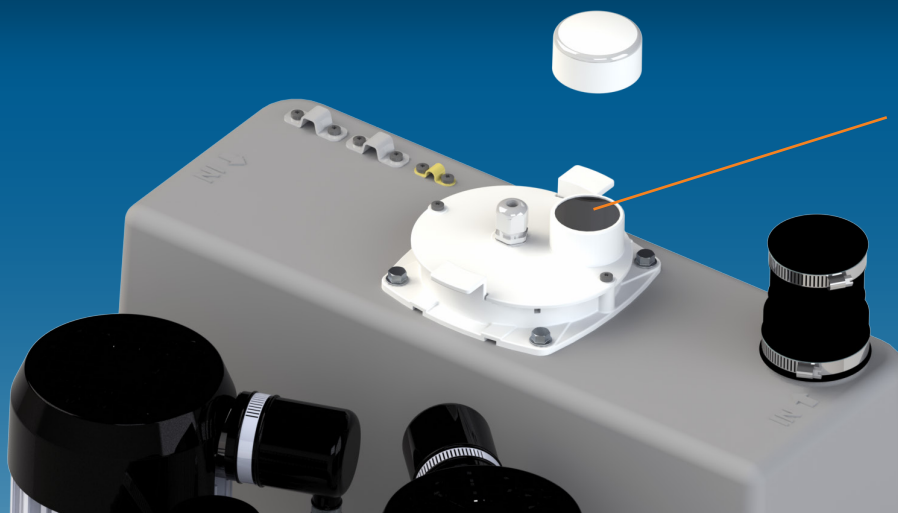

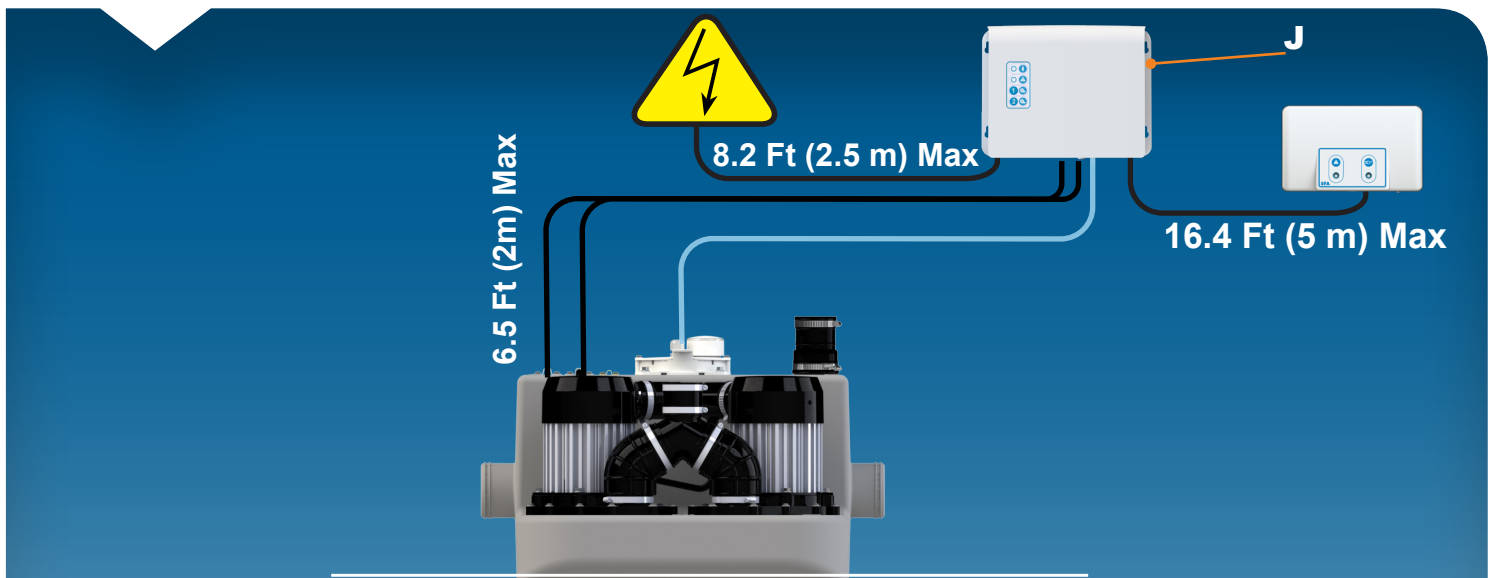
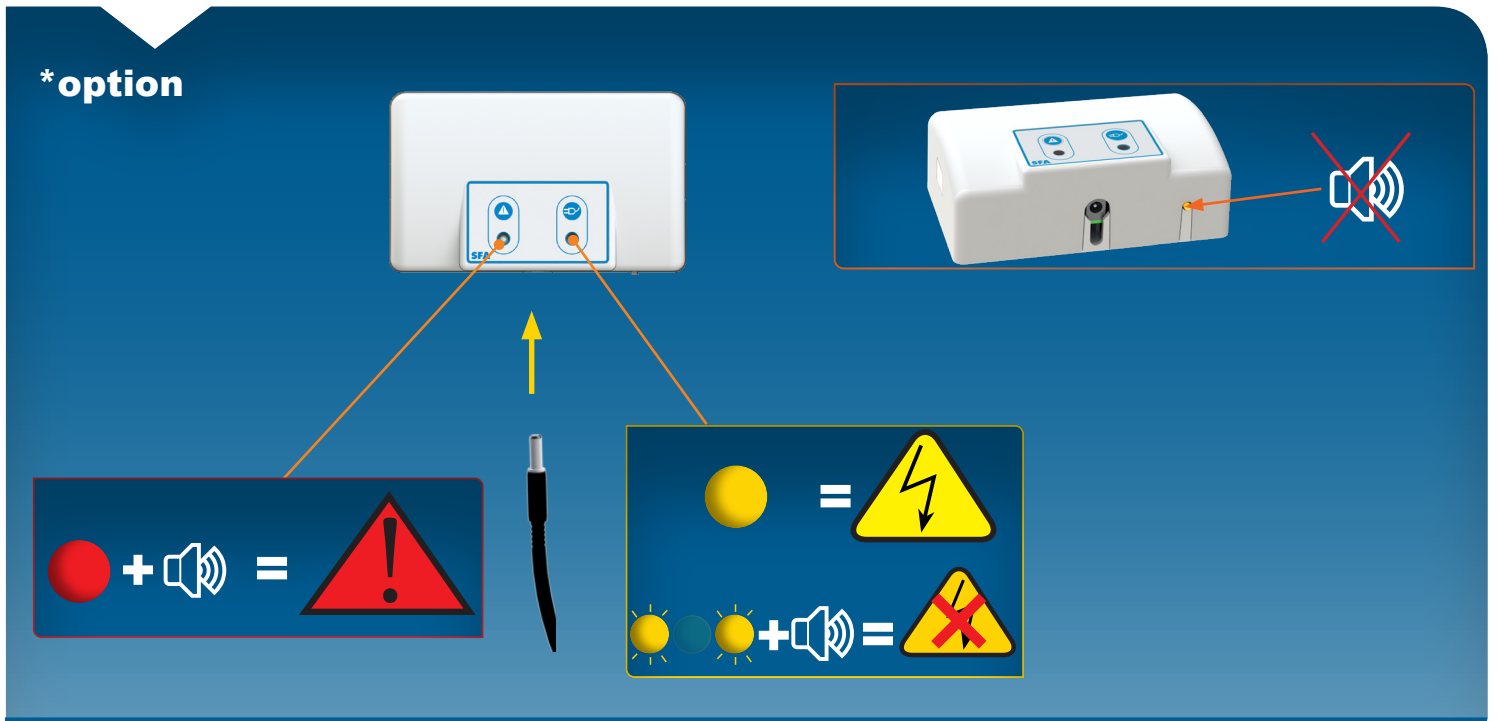
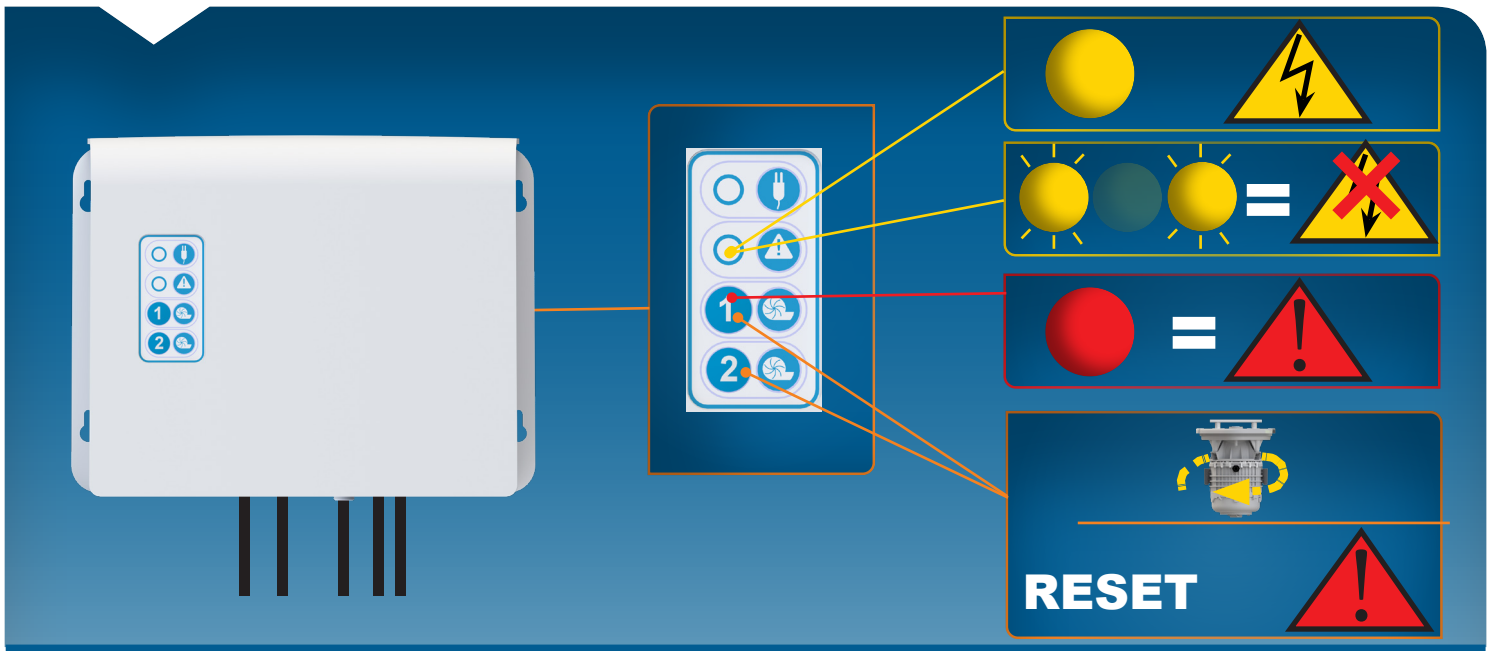

1

ACCESS TO PRESSURE SWITCHES AND BOARD

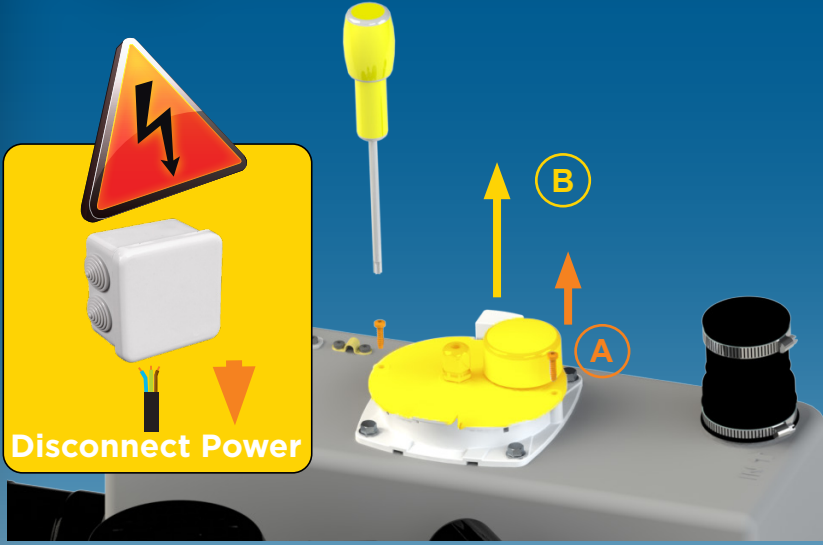

2

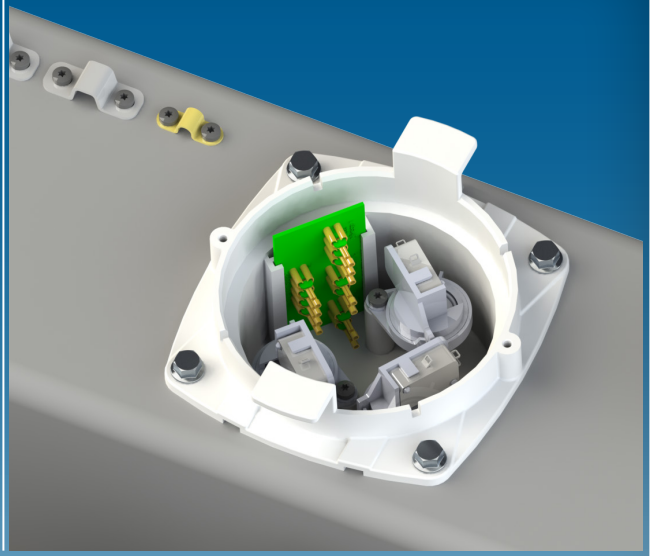

TO REMOVE PRESSURE CHAMBER

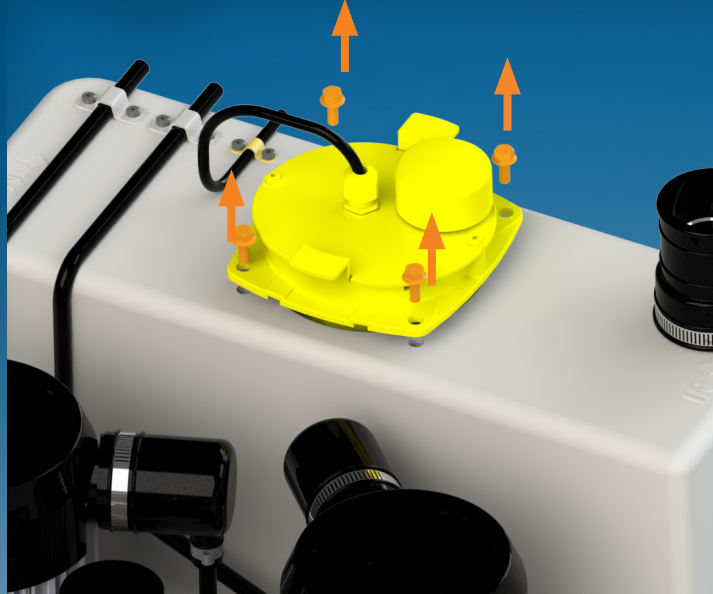

1

TO REMOVE MOTOR



2

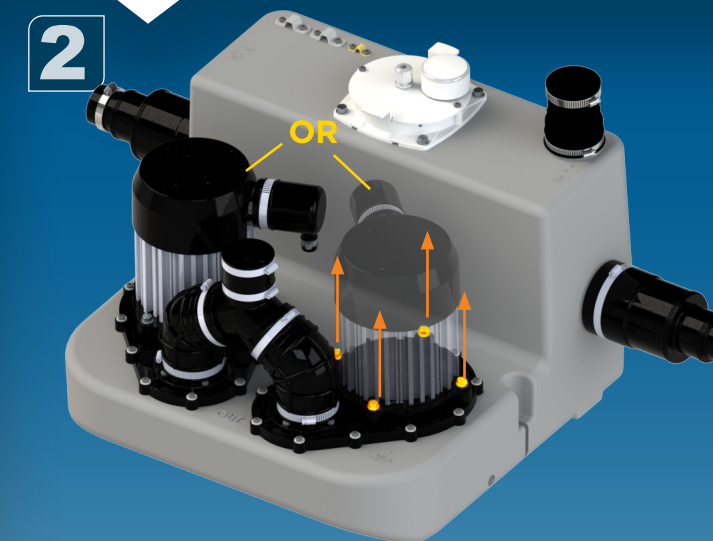

3



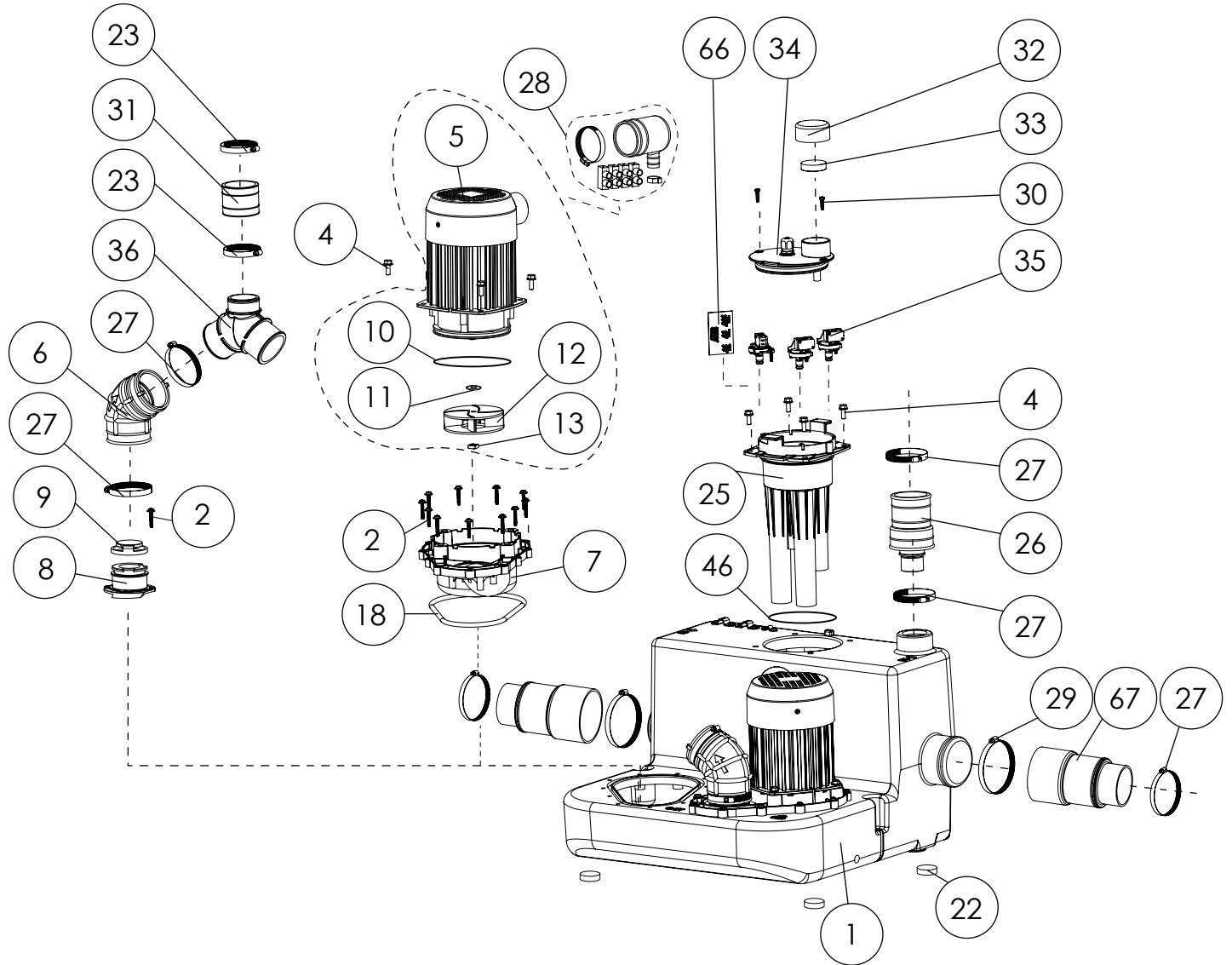
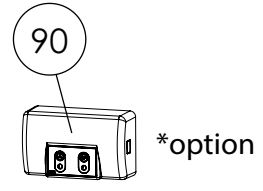
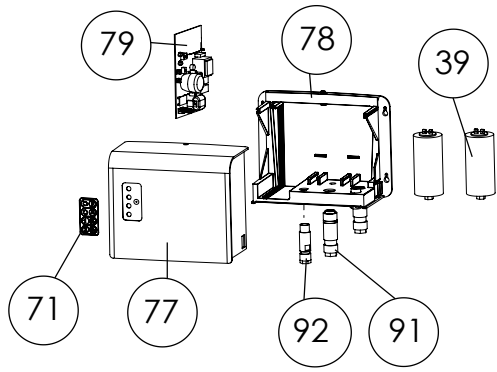



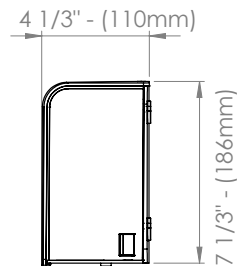
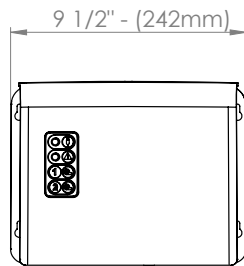
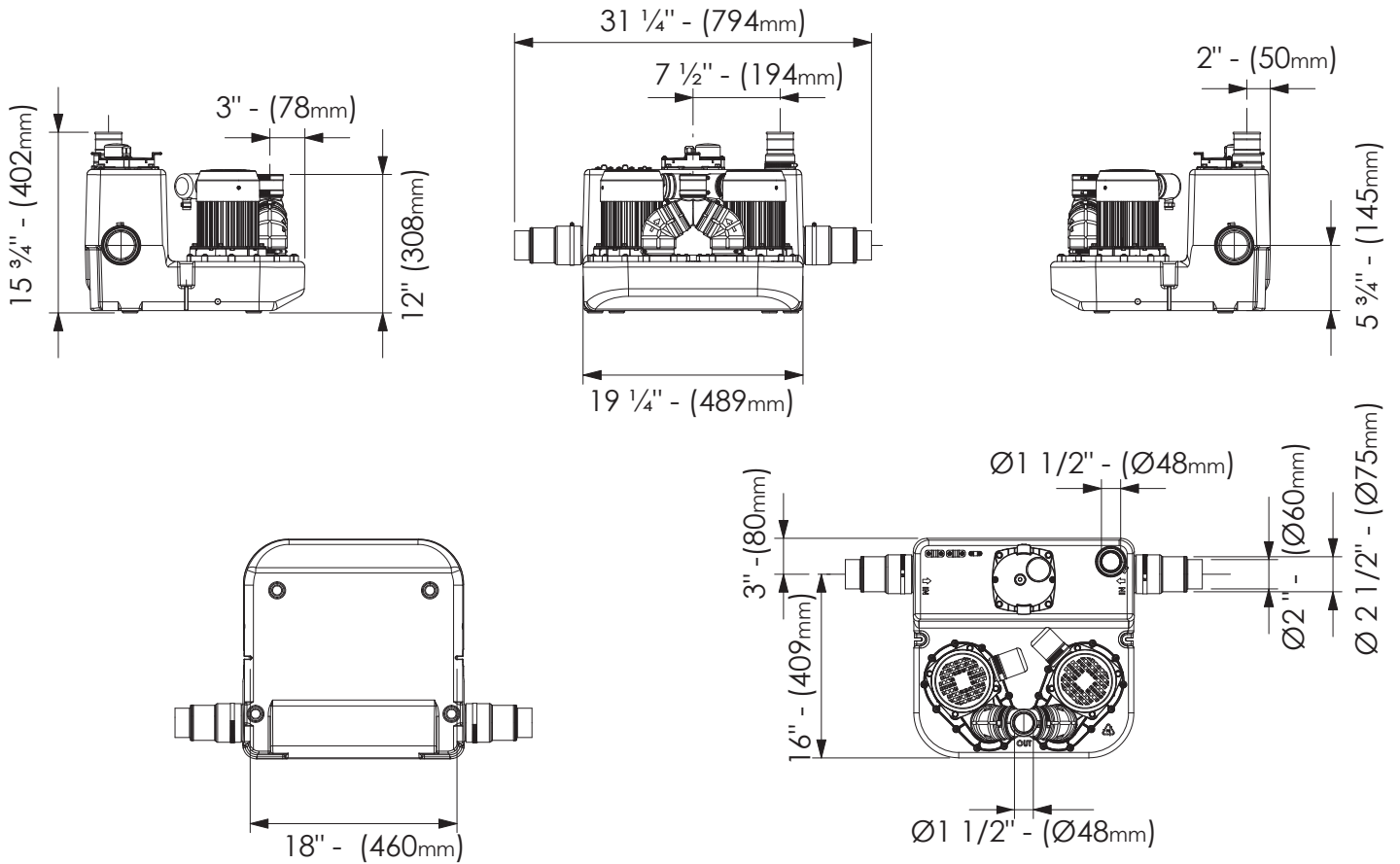

## Sanicom2



220 - 240 V - 60 Hz

2x 2HP CLASS 1 

57 Lbs

Max temperature:

194°F (90°C) for 5Min

Tank volume : 8.5 Gallons

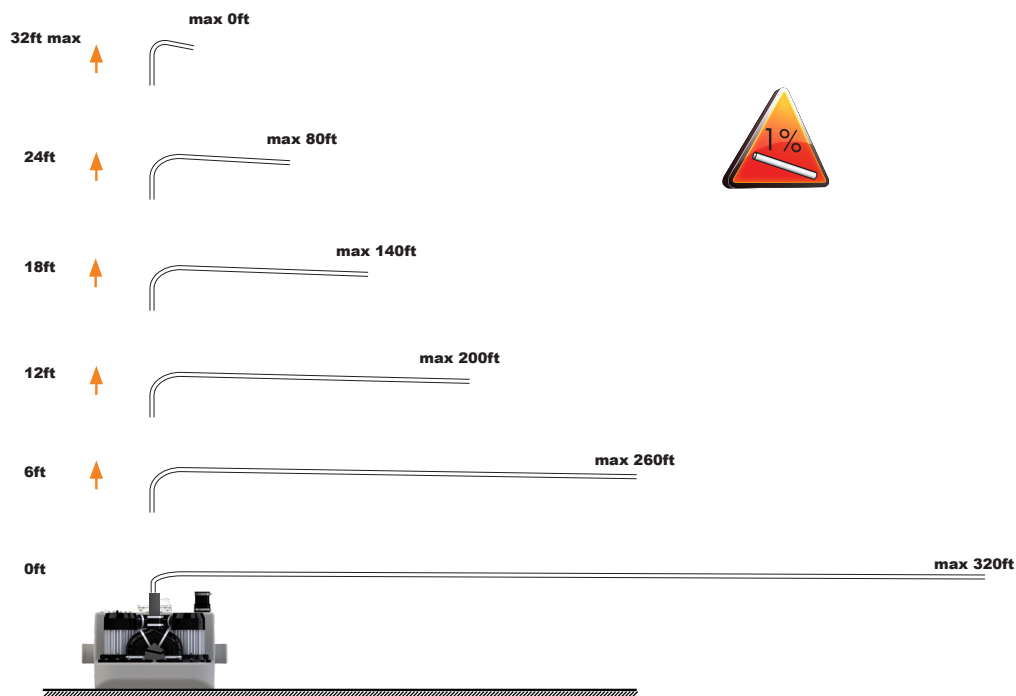
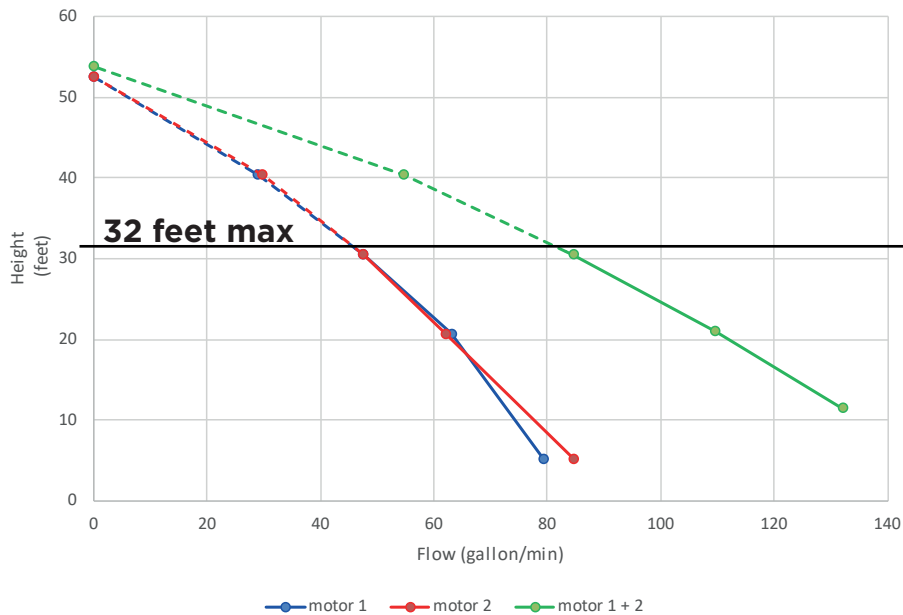

For service or for further inquiries, please call or contact one of the following addresses:  
 Pour le service et d'autres demandes de renseignements, veuillez appeler à l'une des adresses indiquées ci-dessous :

**United States**  
**SFA-SANIFLO INC.**  
 105 Newfield Avenue, Suite A  
 Edison, NJ 08837

**Canada**  
**SFA-SANIFLO INC.**  
 500 Jamieson Parkway, Unit 5  
 Cambridge, ON N3C 0G5

**Toll Free:** 1-800-571-8191  
**Phone:** 1-732-225-6070  
**Fax:** 1-732-225-6072  
**E-mail:** [sfasales@saniflo.com](mailto:sfasales@saniflo.com)  
**Website:** [www.saniflo.com](http://www.saniflo.com)

**Toll Free :** 1-800-363-5874  
**Phone:** 519-824-1134  
**Fax:** 519-824-1143  
**E-mail :** [sales@saniflo.ca](mailto:sales@saniflo.ca) or/ou [ventes@saniflo.ca](mailto:ventes@saniflo.ca)  
**Website:** [www.saniflo.ca](http://www.saniflo.ca) or/ou [www.saniflo.ca/fr](http://www.saniflo.ca/fr)